

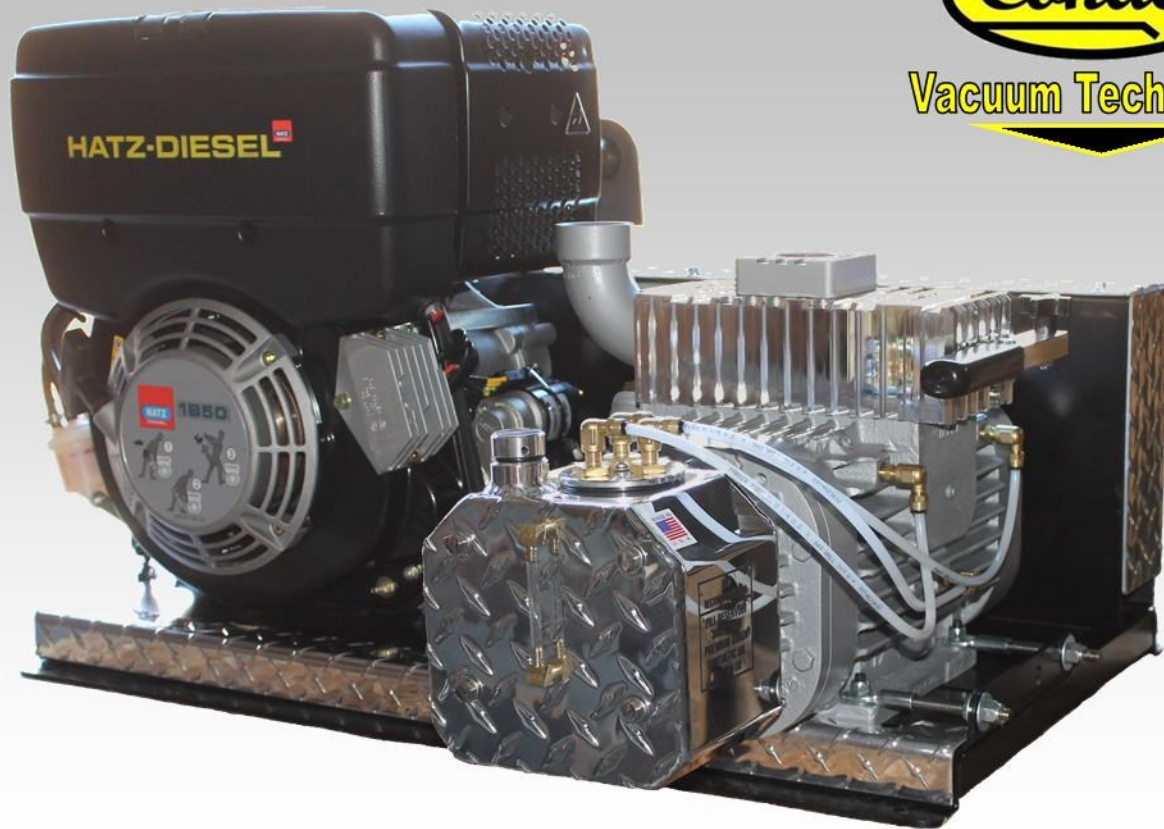

Vacuum Technology



## Conde' SDS ULTRA DIESEL POWERED UNIT

**Conde SDS Ultra Diesel Powered Unit is ideal for applications where sparking is not permitted or diesel power is simply preferred. We use a Hatz Diesel (1B50) air - cooled engine (Certified to EPA Tier IV final) on our rugged platform to power our SDS Ultra (230 CFM) pump. Available in Vacuum only or Vacuum/Pressure models.**

### **SDS ULTRA PUMP**

- . 230 CFM
- . DOUBLE SHAFT DESIGN
- . SHAFT & O-RING SEALS PREVENT LEAKAGE
- . AUTOMATIC OILING, NO ADJUSTMENT
- . HIGH TEMPERATURE SEALED BEARINGS
- . END THRUST PROTECTION

### **HATZ (1B50) DIESEL ENGINE**

- . AIR COOLED
- . ELECTRIC START - 12 VOLT
- . MANUAL 2-SPEED THROTTLE
- . FUEL TANK (5 LITER / 1.32 GALLON)
- . EXHAUST DEFLECTOR (TURNABLE)
- . SPARK ARRESTOR - AVAILABLE

# 12 ULTRA - DIESEL UNIT



Vacuum Technology

## DIMENSIONAL SPECIFICATIONS

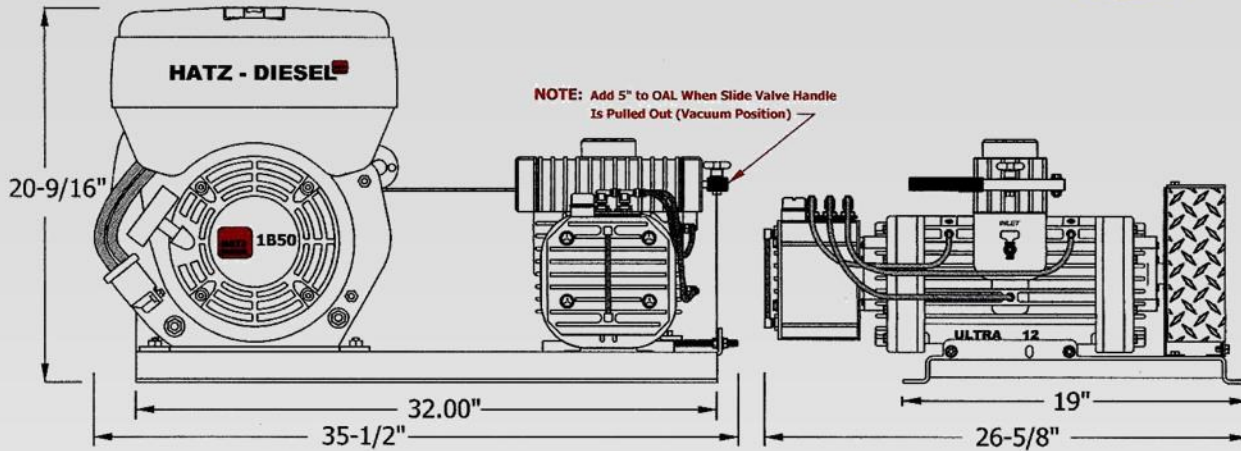

## TECHNICAL SPECIFICATIONS

Part No:	OLUNSDSULTDI	HDUNSDSULTDI
CFM, FREE AIR	230	230
CFM, @ 15" Hg	110	110
HATZ 1B50 DIESEL	ELECTRIC START	ELECTRIC START
HORSEPOWER	10.7 @ 3600 RPM	10.7 @ 3600 RPM
VACUUM/PRESSURE	NO	YES
VACUUM - ONLY	YES	NO
MAXIMUM VACUUM	27" Hg	27" Hg
MAXIMUM PRESSURE	15 PSIG	15 PSIG
OILER	AUTOMATIC	AUTOMATIC
WEIGHT	315 LBS	325 LBS

\*\* Conde Pumps recommends that pressures on tank systems do not exceed 10 psi. Unit pressure relief vents are set at 5 to 10 psig. Pressure vents will relieve tank pressure when unit is shut off. For higher pressures consult factory.

## PERFORMANCE SPECIFICATIONS

Tank Pull Down Time to 15" Hg

TANK SIZE	ULTRA UNIT
500 GALLON	12 SECONDS
750 GALLON	18 SECONDS
1000 GALLON	24 SECONDS
1500 GALLON	36 SECONDS
2000 GALLON	47 SECONDS

**WESTMOOR LTD.**  
**906 WEST HAMILTON AVE**  
**SHERRILL, NEW YORK 13461**



**MANUFACTURERS OF CONDE PUMPS AND EQUIPMENT**

**PHONE: 800-367-0972**

**WEB: WWW.WESTMOORLTD.COM**

**FAX: 315-363-0193**