

# DIMENSIONAL SPECIFICATIONS

MANUFACTURERS OF:  VACUUM TECHNOLOGY

**MADE IN USA**

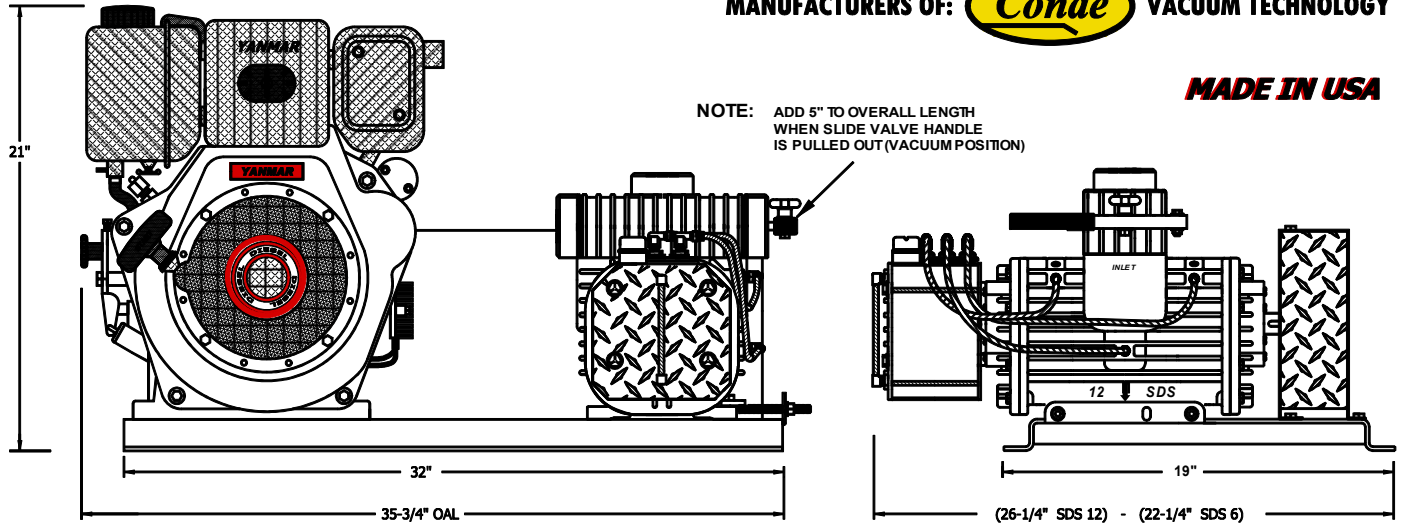

# TECHNICAL SPECIFICATIONS

PART NO.	OLUN06SDS10DI	HDUN06SDS10DI	OLUN12SDS10DI	HDUN12SDS10DI
CFM, FREE AIR	115	115	180	180
CFM, 15" HG	55	55	90	90
HORSEPOWER	10 HP	10 HP	10 HP	10 HP
YANMAR EL. START	DIESEL	DIESEL	DIESEL	DIESEL
VACUUM/PRESSURE	NO	YES	NO	YES
VACUUM - ONLY	YES	NO	YES	NO
MAX. VACUUM	27" HG	27" HG	27" HG	27" HG
MAX. PRESSURE **	15 PSIG	15 PSIG	15 PSIG	15 PSIG
WEIGHT	295 LBS.	305 LBS.	325 LBS.	335 LBS.
PUMP OILER	AUTOMATIC	AUTOMATIC	AUTOMATIC	AUTOMATIC

\*\* Conde Pumps recommends that the pressures on tank systems do not exceed 10 PSI. Unit pressure relief valves are set @ 5 to 10 PSIG. Pressure Vents will relieve tank pressure when unit is shut off. For higher pressures consult factory.

# PERFORMANCE SPECIFICATIONS

## TANK PULL DOWN TIME TO 15" HG

TANK SIZE	SDS 6, 10 HP	SDS 12, 10 HP
500 GALLONS	23 SEC.	14 SEC.
750 GALLONS	35 SEC.	21 SEC.
1000 GALLONS	47 SEC.	28 SEC.
1500 GALLONS	70 SEC.	42 SEC.
2000 GALLONS	93 SEC.	56 SEC.

**WESTMOOR LTD.  
906 WEST HAMILTON AVE  
SHERRILL, NY 13461**

**PHONE: 800-367-0972  
FAX: 315-363-0193**

**VISIT US ONLINE @ [WWW.WESTMOORLTD.COM](http://WWW.WESTMOORLTD.COM)**